

- 1 TYCO TRADEMARK LOCATED IN APPROX AREA SHOWN.
- 2 STANDOFFS: POSN 10 (8) STANDOFFS AS SHOWN.
 POSN 14 (11) STANDOFFS, 3 PER DIAGONAL ROW.
 POSN 18 (14) STANDOFFS, 3 PER DIAGONAL ROW.
 POSN 22 (17) STANDOFFS, 3 PER DIAGONAL ROW.
 POSN 26 (20) STANDOFFS, 3 PER DIAGONAL ROW.
 POSN 30 (23) STANDOFFS, 3 PER DIAGONAL ROW.
 POSN 34 (26) STANDOFFS, 3 PER DIAGONAL ROW.
 POSN 38 (29) STANDOFFS, 3 PER DIAGONAL ROW.
 POSN 42 (32) STANDOFFS, 3 PER DIAGONAL ROW.
 POSN 46 (35) STANDOFFS, 3 PER DIAGONAL ROW.
 POSN 50 (38) STANDOFFS, 3 PER DIAGONAL ROW.
 POSN 54 (41) STANDOFFS, 3 PER DIAGONAL ROW.
 POSN 58 (44) STANDOFFS, 3 PER DIAGONAL ROW.
- 3 FINISH: BRIGHT TIN-LEAD .000100-.000200 THK OVER NICKEL .000050 MIN THK.
- 4 HEIGHT AFTER TERMINATION IS .238 REF.
- 5 FINISH: BRIGHT TIN .000100-.000200 THK OVER NICKEL .000050 MIN THK.

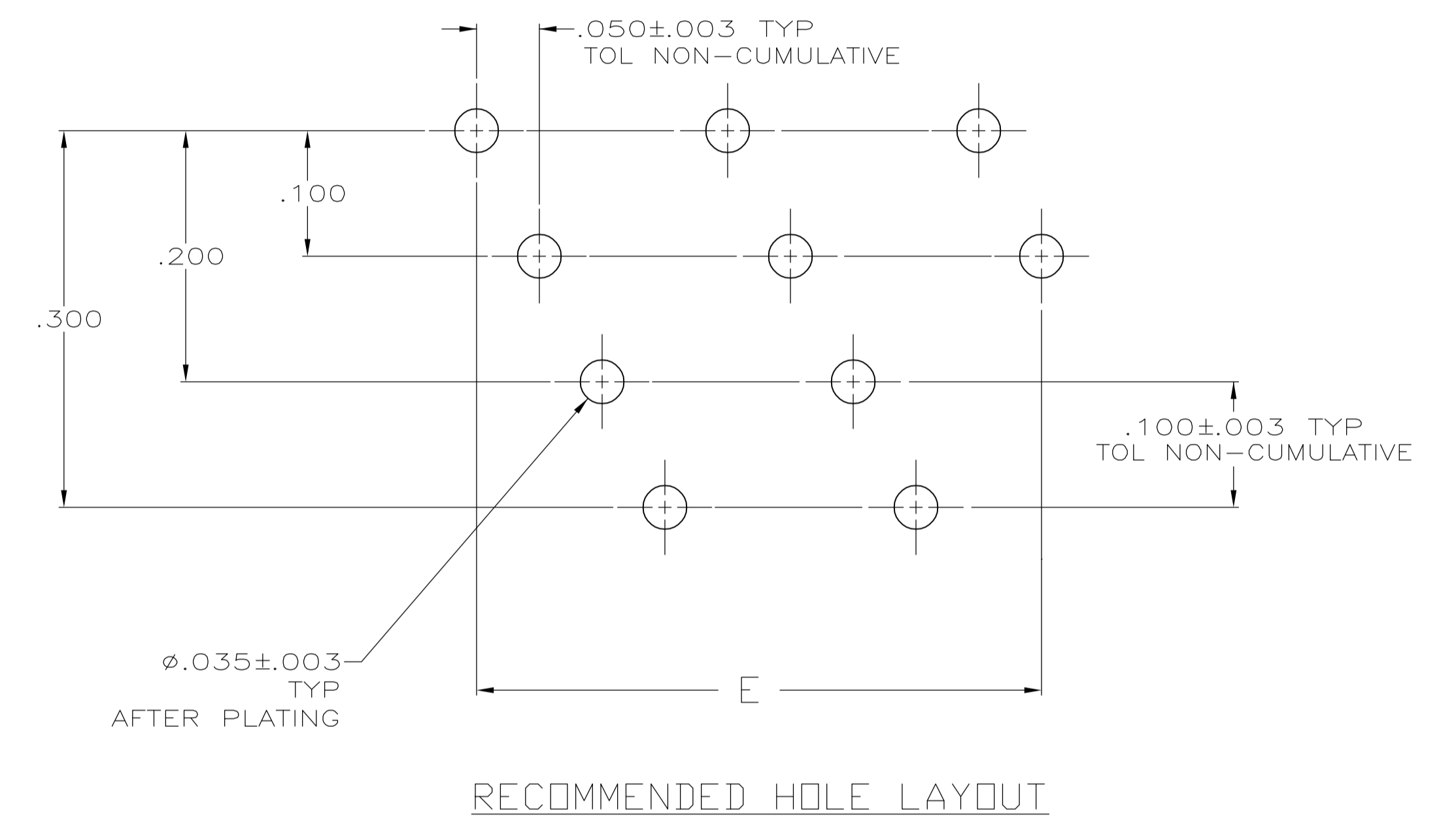

| | | | | | | | | | |
|----------|---|-------|-------|-------|-------|-------|------------|----|-------------|
| | 5 | 2.450 | 2.450 | 2.774 | 2.450 | 2.450 | 49 | 50 | 6-111037-1 |
| | 5 | 1.650 | 1.650 | 1.974 | 1.650 | 1.650 | 33 | 34 | 5-111037-7 |
| | 5 | 1.450 | 1.450 | 1.774 | 1.450 | 1.450 | 29 | 30 | 5-111037-6 |
| | 5 | 1.250 | 1.250 | 1.574 | 1.250 | 1.250 | 25 | 26 | 5-111037-5 |
| | 5 | .650 | .650 | .974 | .650 | .650 | 13 | 14 | 5-111037-2 |
| | 5 | .450 | .450 | .774 | .450 | .450 | 9 | 10 | 5-111037-1 |
| OBSOLETE | 3 | 2.850 | 2.850 | 3.174 | 2.850 | 2.850 | 57 | 58 | 1-111037-3 |
| OBSOLETE | 3 | 2.650 | 2.650 | 2.974 | 2.650 | 2.650 | 53 | 54 | 1-111037-2 |
| | 3 | 2.450 | 2.450 | 2.774 | 2.450 | 2.450 | 49 | 50 | 1-111037-1 |
| OBSOLETE | 3 | 2.250 | 2.250 | 2.574 | 2.250 | 2.250 | 45 | 46 | 1-111037-0 |
| OBSOLETE | 3 | 2.050 | 2.050 | 2.374 | 2.050 | 2.050 | 41 | 42 | 111037-9 |
| OBSOLETE | 3 | 1.850 | 1.850 | 2.174 | 1.850 | 1.850 | 37 | 38 | 111037-8 |
| | 3 | 1.650 | 1.650 | 1.974 | 1.650 | 1.650 | 33 | 34 | 111037-7 |
| | 3 | 1.450 | 1.450 | 1.774 | 1.450 | 1.450 | 29 | 30 | 111037-6 |
| | 3 | 1.250 | 1.250 | 1.574 | 1.250 | 1.250 | 25 | 26 | 111037-5 |
| OBSOLETE | 3 | 1.050 | 1.050 | 1.374 | 1.050 | 1.050 | 21 | 22 | 111037-4 |
| OBSOLETE | 3 | .850 | .850 | 1.174 | .850 | .850 | 17 | 18 | 111037-3 |
| | 3 | .650 | .650 | .974 | .650 | .650 | 13 | 14 | 111037-2 |
| | 3 | .450 | .450 | .774 | .450 | .450 | 9 | 10 | 111037-1 |
| FINISH | F | E | D | C | B | A | NO OF POSN | | PART NUMBER |

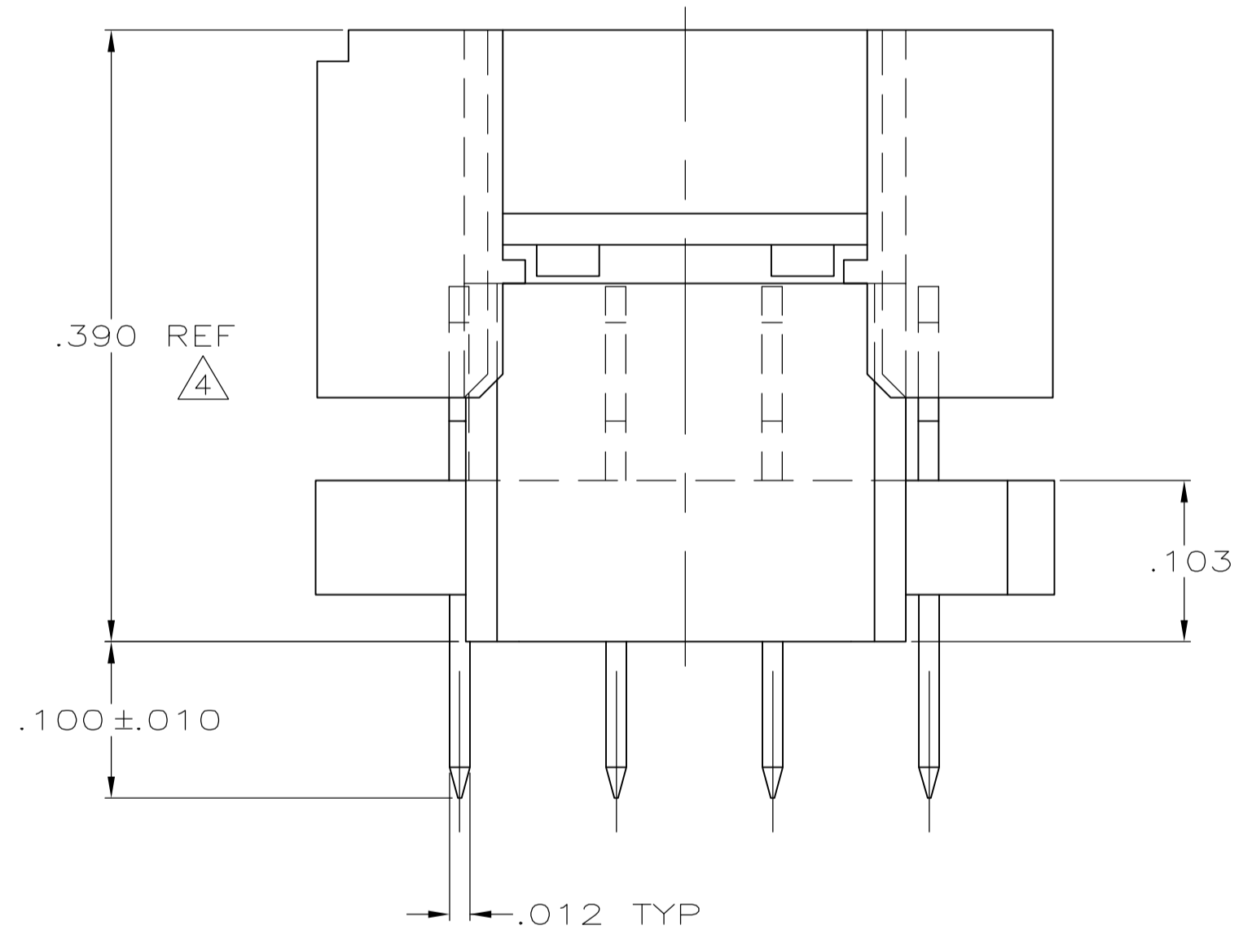
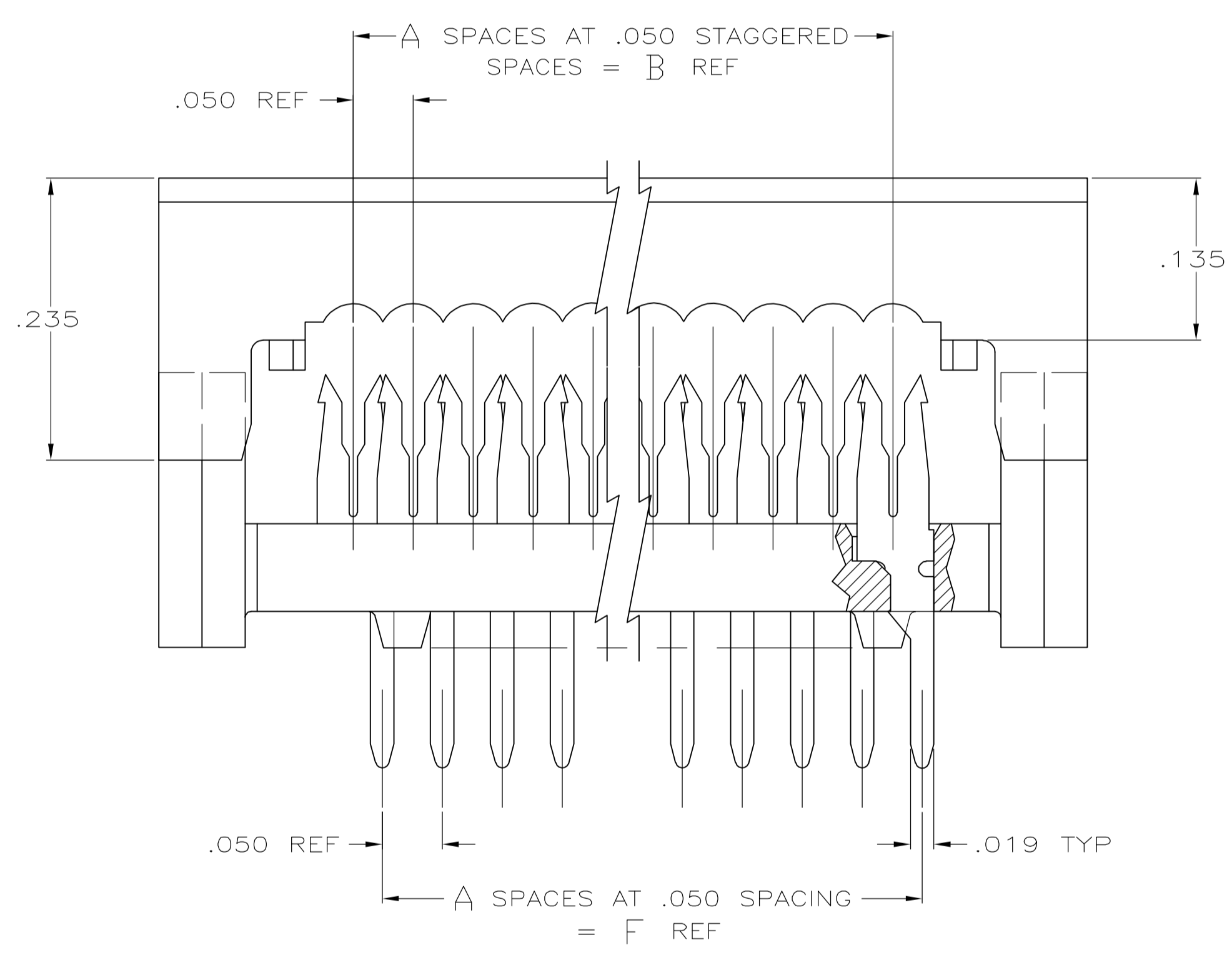
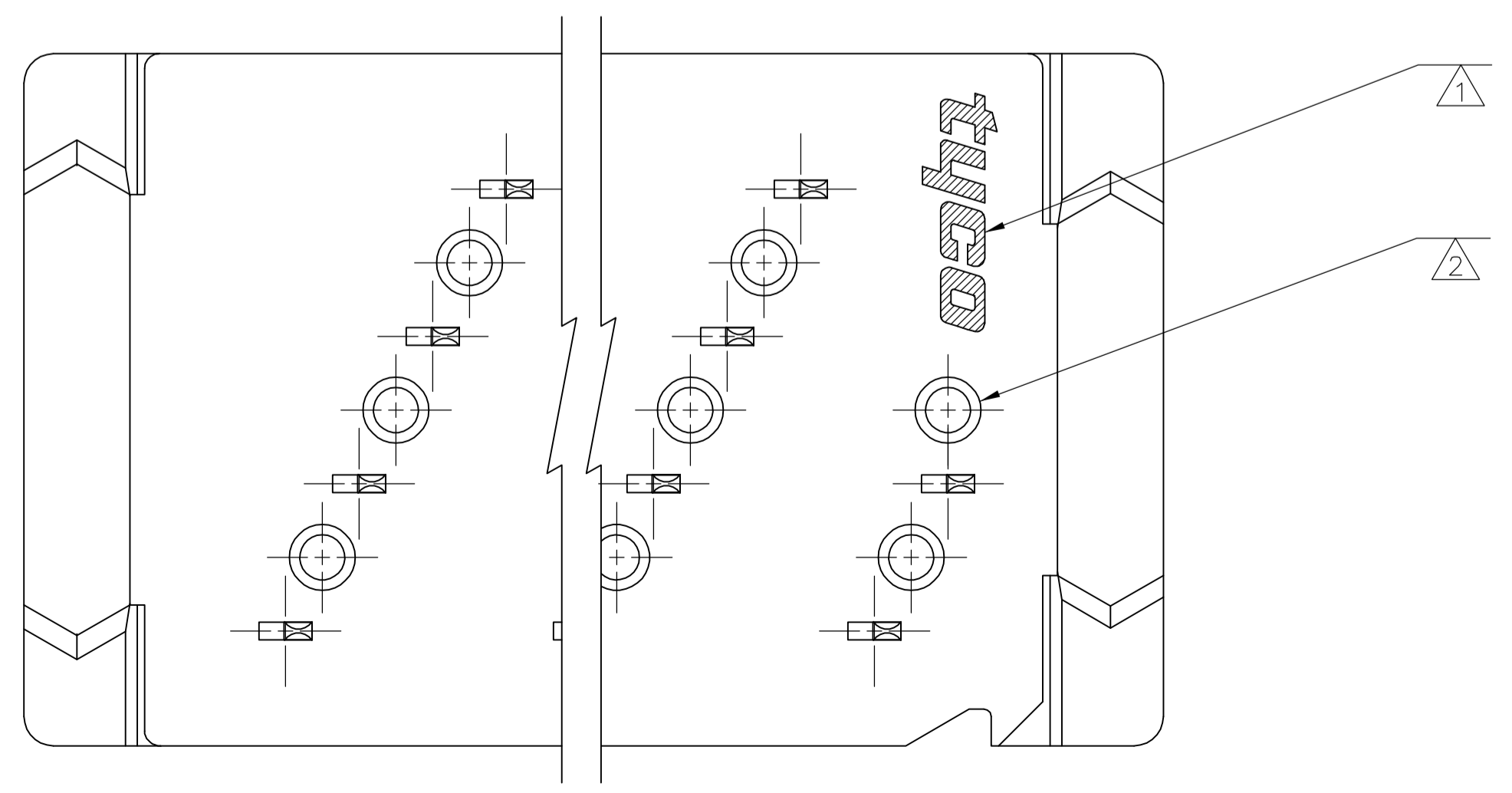

THIS DRAWING IS A CONTROLLED DOCUMENT.

| | | | | | | | |
|--------------------|--|-----------|-----------|-----------|--------------|-----------|------------|
| DIMENSIONS: INCHES | TOLERANCES UNLESS OTHERWISE SPECIFIED: | 0 PLC ± - | 1 PLC ± - | 2 PLC ± - | 3 PLC ± .005 | 4 PLC ± - | ANGLES ± - |
|--------------------|--|-----------|-----------|-----------|--------------|-----------|------------|

MATERIAL: MOLDED PARTS: 94V-0 RATED THERMOPLASTIC, COLOR BLACK CONTACTS: PH BRZ PER QQ-B-750

FINISH: CONTACTS

THIS DRAWING IS A CONTROLLED DOCUMENT. DIN J. PEACHEY 05-MAR-86. CHK M. SCULLY 23-MAY-86. AP'D D. HOFFMAN 23-MAY-86. NAME: KIT, AMP-LATCH PADDLEBOARD PREASSEMBLED, .100 LONG POSTS SHORT END, FULL TIN PLATED CONTACTS

SIZE: A1. CAGE CODE: 114-40005. DRAWING NO: 00779. REV: 111037. SCALE: 10:1. SHEET: 1 OF 1. REV: H.